

we also create waves...

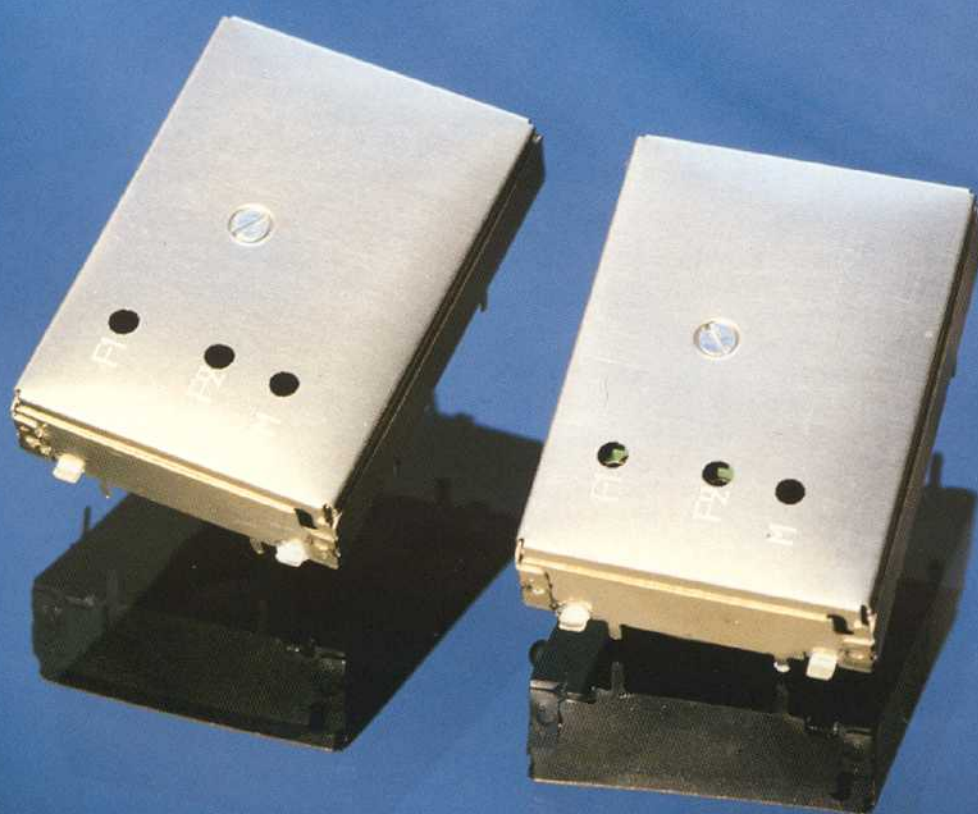

TU5D -optional second channel
Radio Modules

MINIATURE UHF RADIO MODULES FOR WIRELESS DATA AND TELEMETRY

GENERAL

The **TU5D** UHF Radio Modules are intended for short and medium range wireless data and telemetry applications, in- and outdoors. As the transmitter and the receiver are enclosed in separate metal housings, they are optimal for both two- and one-way wireless links.

By very careful design, two-level FSK modulation has been found to facilitate 9600 b/s data speed on 25 kHz channel separation, 4800 b/s on 12.5 kHz. The built-in filtering in the transmitter, and data detector in the receiver, can make the external modem redundant in most applications. However, to provide the maximum flexibility, the **TU5D** Radio Modules can be used with external modems in wireless data and/or telemetry applications. The low frequency response extends from DC to 4.8 kHz, and DC to 2.4 kHz, at 25 and 12.5 kHz channel spacings, respectively.

These Radio Modules can be furnished with two plug-in oscillator modules, facilitating real dual channel operation and easy changing of the operating frequencies afterwards, even without re-tuning.

SHORT FORM SPECIFICATIONS

Frequency coverage: 400 to 470 MHz; 7 pre-tuned versions, each covering 10 MHz
 Number of channels: 1 as standard, optional second channel can be added afterwards
 Channel separation: 12.5, 20 or 25 kHz
 Temperature range: -20 to +55 deg.C standard, special versions available down to -30 deg.C
 Supply voltage: +6 to +8 V
 Physical dimensions: Width: 36 mm; Height: 13.5 mm; Length: 54 mm, including tabs at both ends
 1 W version: width: 37 mm, height: 13.5 mm, length: 56 mm
 Connection in and out: by means of pins at the bottom, pitch: 2.54, diam.: 0.5, length: 3 mm either for direct soldering to a PCB or plugging into PCB sockets
 Compliant to: I-ETS300113; pri-ETS300220; CEPT 20-04; CEPT 24-01; MPT1329; MPT1326
 Several versions available depending on the severity of type approval specifications.

TRANSMITTER

Output Power: TUS5nD: adjustable from 10 to 50 mW
 TUT5nD: 400 mW nominal
 TUW5nD: 1W nominal
 Modul.input: 1Vp-p to ampl./limiter
 2 Vp-p to modulator
 Supply current: depends on output power
 400 to 435 MHz: n=1 , 435 to 470 MHz: n=2

RECEIVER

Sensitivity: -113dBm; I-ETS300113 method
 Analog outputs: 1 Vp-p to >15 kohms at nominal deviation
 Data output: CMOS-compatible
 RSSI-output: +0.5 to +4V to >1 Mohms
 Supply current: 25 to 35 mA for terminal/base

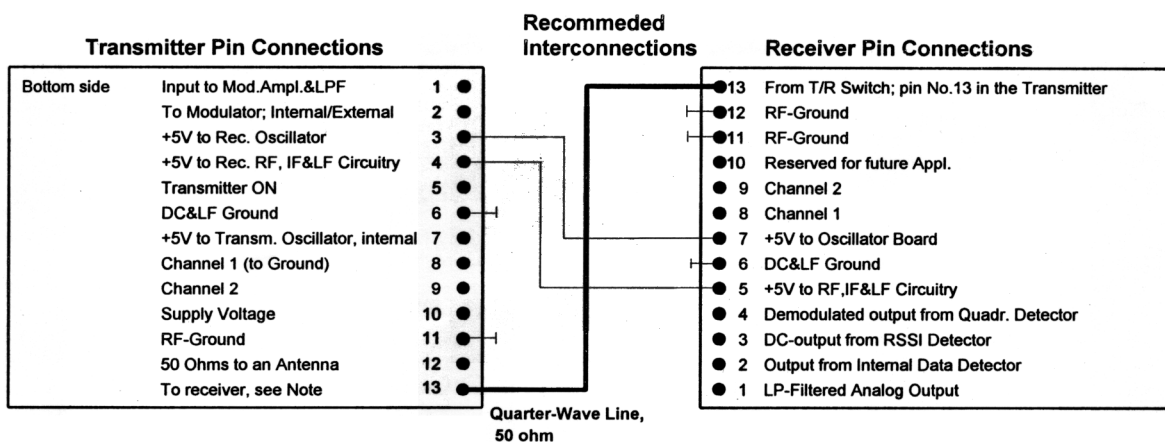

Produced by:

Your supplier:

ULTRACOM OY
 Address: P.O.Box 20, 90441 Kempele, FINLAND
 Street Address: Tarjusojantie 11, Kempele
 Telephone: INT+ 358 8 520 8686
 Telefax: INT+ 358 8 520 8717